



Close door and disconnect power to the garage door opener before proceeding.

The trolley must be in down (closed door) position during assembly and installation. If you have a completely installed garage door opener, the rail/opener assembly must be taken down. UP and DOWN Limits must be readjusted after installation.

Opener hanging brackets will require repositioning due to increased rail length.

If this is a new installation, replace the front (header) rail in your opener carton with the longer one in this kit. Add the center rail in this kit as the second or third rail, creating a four rail assembly. Use the chain/cable assembly and longer emergency release rope in this kit in place of those packaged with your opener. Complete the assembly, installation, and adjustment of your opener according to your Owner's Manual.

If this is an existing installation, continue as follows:

1. Pull down on the emergency release handle, then disconnect the trolley from the door arm.
2. Disconnect the rail/opener assembly from the header bracket and hanging brackets, and place it on the floor.
3. Remove the sprocket cover from the powerhead and set aside.
4. Remove the outer nut (Figure 1) from the trolley shaft and set aside.
5. Disconnect the two master link assemblies from the trolley (Figure 2) and discard.
6. Remove idler pulley assembly and set aside.
7. Remove the chain/cable assembly and discard.
8. Remove the 1/4"-20x1-3/4 bolt and lock nut from the trolley stop hole in the front rail and set aside.
9. Push the trolley back toward the opener head. Disconnect the front rail section by using a screwdriver tip to pry up the outer tab on each side of the rail (Figure 3), then slide it off the center rail. Discard the front rail.
10. Align the new front and center rails with the existing rail assembly, keeping the small holes along the same edge, and the cut out "window" at the front (header) end. Be sure to keep rails right side up: *the idler pulley bolt hole above the window is larger on top of the rail than on the bottom.* Slide the new center rail onto the assembly, then add the front rail. Tabs along the side will lock into place.
11. As a temporary trolley stop, clamp a locking pliers onto the rail, 8" from the center of the idler pulley hole, as shown in Figure 4. Slide the trolley assembly to this point.
12. Refer to your owner's manual to complete the assembly, re-installation and adjustment of your opener
13. Replace the old emergency release rope with the new, longer replacement rope.
14. Reconnect power and operate the door in the UP direction.
15. Increase the UP travel limit by turning the UP limit adjustment screw in a clockwise direction as shown on label. One turn equals 2" of travel.

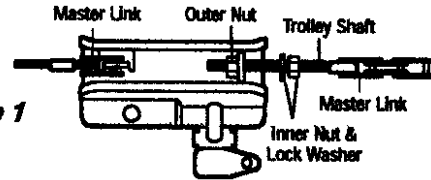

Figure 1

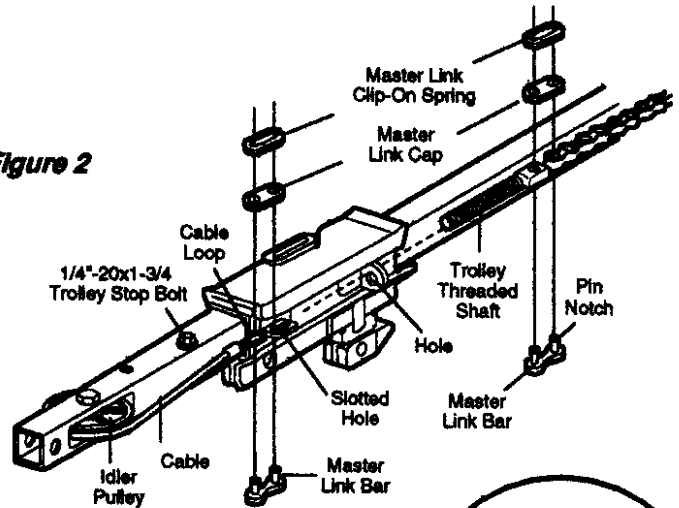

Figure 2

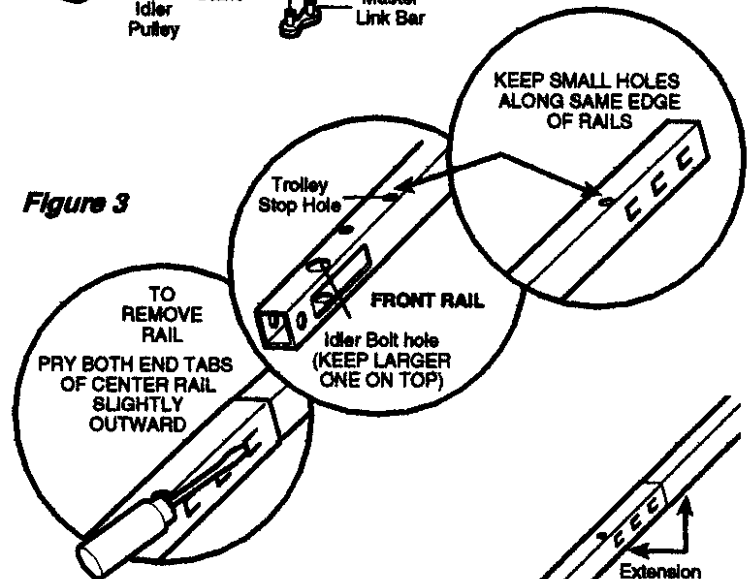

Figure 3

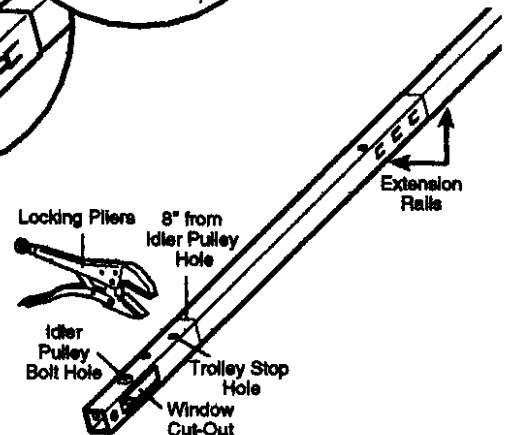

Figure 4

Part No.	Description	Qty
183C158-11	Header rail extension	1
183C157-8	Center rail section	1
1A5249-2	10' Chain/Cable Assembly	1
26A53	Rope	1
1A995	Master Link Kit	1