

RM-120A
Speaker Station

INSTRUCTION
and
SERVICE MANUAL



945 Camelia St. Berkeley, California 94710 510-527-6666

**CLEAR-COM RM-120A SPEAKER STATION
OPERATION MANUAL**

TABLE OF CONTENTS

| <u>Section</u> | <u>Page #</u> |
|---|---------------|
| I Introduction to the RM-120A..... | 1 |
| II Headsets and Mics..... | 2 |
| III Installation..... | 3 |
| IV Operating Controls & Connectors..... | 4 |
| V Specifications..... | 7 |
| VI Parts Listing..... | 8 |
| <u>Illustrations</u> | |
| Headset Extension Cord..... | 2 |
| RM-120A Rear Panel..... | 3 |
| Daisy-Chain Interconnection..... | 3 |
| RM-120A Front Panel..... | 4 |
| RM-120A Schematics..... | 9 |

NOTICE:

"While Clear-Com makes every attempt to maintain the accuracy of the information contained in its product manuals, the information is subject change without notice."

** DOCUMENTATION ADDENDUM **
** RM-120A MANUAL **
** REV.A **
** November 17, 1987 **
** *****

MIC TO LINE GAIN LEVEL INCREASE

In effecting a 4dB Mic to Line increase in gain level, the following changes have been made:

| <u>Change:</u> | <u>At:</u> | <u>To:</u> |
|----------------|------------|------------|
| 100K OHM | R50, R51 | 220K OHM |
| 1.5K OHM | R23 | 2.7K OHM |

I. INTRODUCTION TO THE RM-120A SPEAKER STATION

The RM-120A is a remote speaker station that allows selectable communicating in the Clear-Com System. The operator can talk and listen on Channel A, Channel B, or both at once (without tying them together).

The RM-120A mounts in a 19" rack, using just 1.75" vertical space. It features a wide frequency response speaker and operates with a carbon headset or a dynamic headset/telephone-style handset.

The rear panel provides a 1/4" jack for output to an external speaker (using it disconnects the internal speaker). The operator can turn down the volume of the built-in or external speaker to have a private conversation with a headset. Alternately, the gooseneck or headset mic can be turned off to use the RM-120A for "listen-only" (paging).

The RM-120A provides a balanced program input for monitoring external audio in the speaker or headset. The RM-120A mixes the program with the intercom signal for monitoring in the headset and/or speaker. The station provides separate controls for adjusting intercom and program volume levels.

The "Stage Announce" feature is for paging applications. The RM-120A provides a balanced, line-level output signal to a 1/4" phone jack (on the rear panel). The Stage Announce button on the front panel activates this output, giving the operator access to an external speaker/amp system. Pressing Stage Announce mutes the operator's voice to the intercom channels.

Visual Signalling is a standard Clear-Com feature. The "Call" button attracts the attention of intercom users who have removed their headsets or turned off their speakers (it can also activate remote control of KB-112 Stations). The

RM-120A provides a Call button to signal stations on the channel(s) chosen with the "Channel Select" toggle switch. Each channel has a lamp to indicate incoming signals, regardless of the Channel Select switch position.

The RM-120A sidetone control allows the operator to adjust the level of his/her own voice as heard in the station's headset/speaker. Sidetone control helps to prevent acoustic feedback when using the speaker and gooseneck mic simultaneously. You need only adjust sidetone when you set up the system (if at all), not when other stations join or leave the intercom system.

The RM-120A provides excellent speech intelligibility in all surroundings. It features "Automatic Headset Detection," which shuts off the mic preamp when a headset is not plugged in. This prevents noise pick-up on the intercom line from the unused connector. The RM-120A also incorporates a mic limiter, which assures constant talk levels and prevents overload.

Gooseneck Mic Option

The RM-120A is available with a noise-cancelling electret mic on a flexible gooseneck. Though permanently attached, the length of the gooseneck is field-adjustable. The electret element has unusually high immunity to ambient room noise and speaker feedback, thus permitting practical "hands-free" operation. You activate the mic by setting the Mic On/Off/(On) switch to "(On)" (momentary on), which attenuates the speaker by 6 dB to reduce the possibility of feedback.

The RM-120A provides two 3-pin, XLR connectors for each channel (4 total; two inputs, two extensions). Standard two-conductor, shielded mic cable connects the RM-120A to the intercom system.

II. HEADSETS AND MICS

The RM-120A provides:

- one 1/4" phone jack for a standard carbon headset, AND
- one 4-pin, male, XLR connector for dynamic headset, telephone handset, or push-to-talk mic.

NOTE: If you simultaneously use a carbon headset and a dynamic headset, the level in the carbon headset drops audibly.

Carbon headset connections:

Ring-----Headphone
Tip-----Mic
Sleeve---Ground

To assure proper level and performance, the carbon headset's mic impedance should be 50 ohms, and earphone impedance should be 300-2000 ohms.

Dynamic headset connections:

Pin 1----Mic Ground
Pin 2----Mic Hot
Pin 3----Headphone Ground
Pin 4----Headphone Hot

To assure proper level and performance, the dynamic headset should have the following characteristics:

Mic Impedance: 150-250 ohms
Nominal Output Level: -55 dBv
Headphone Type: dynamic
Impedance: 300-2000 ohms

The RM-120A's built-in headset amplifier can drive a headset to levels greater than 110 dB SPL, and drives two dynamic headsets with only a 3 dB reduction in level when connected with the proper "Y" cord.

It's easy to make an extension cord for your dynamic headset. For the cable, we recommend Belden 8416 or the equivalent (2-conductor, 25-gauge) or Belden 8734 or the equivalent (3-conductor, 22-gauge). See the diagram below. The cord length should be 15 feet or less; anything longer might lead to capacitive coupling between mic signal and headset signal, causing oscillation or a loss in frequency response.

Caution: Do not connect mic ground and headphone ground together.

Figure 1: Headset Extension Cord

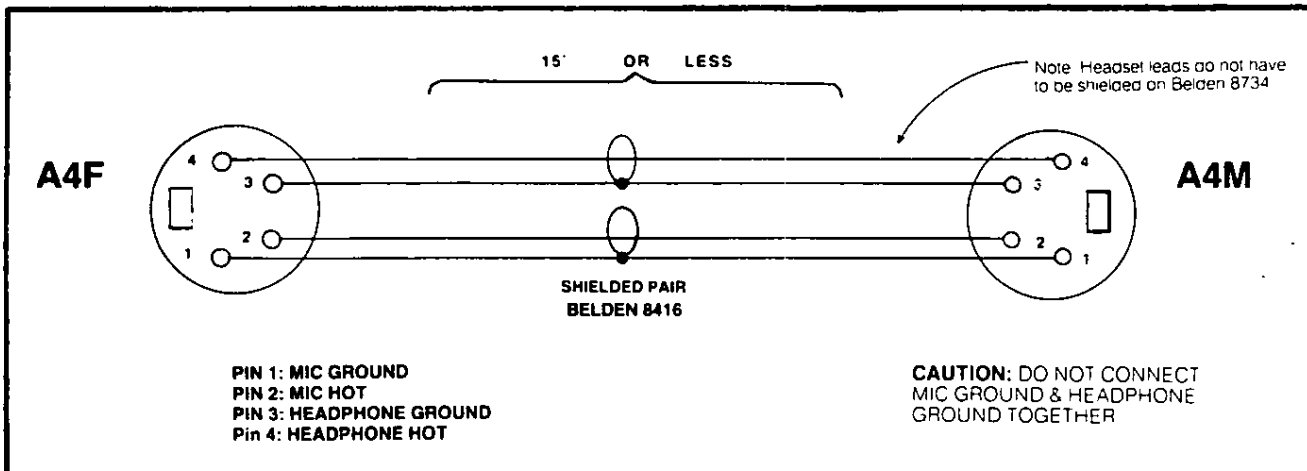

III. RM-120A INSTALLATION

The RM-120A connects to the intercom system via two pairs of 3-pin, XLR connectors on the rear panel.

- 1) Route each channel on a separate, two-conductor, shielded mic cable (e.g. Belden 8413) from the Main Station intercom output connectors to the rack location of the RM-120A.
- 2) Rack-mount the RM-120A and then apply the intercom inputs to the appropriately labelled (Channel A or Channel B) 3-pin female connectors (on the rear panel).

The 3-pin male connectors provide a hard-wired loop-through for each channel, which allows extension ("daisy-chaining") of the intercom lines to other stations in the system.

The pin assignments for all intercom connectors are:

- Pin 1: Common
- Pin 2: +30 VDC
- Pin 3: Intercom Audio
Ch. A or B

CHASSIS DEPTH
6.62"
(168.15)

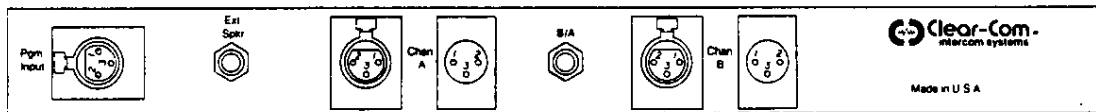

- 3) **Program Input:** the RM-120A rear panel contains a 3-pin female connector for input of a balanced, line-level auxiliary input. Pin 1 is ground, and Pins 2 and 3 are hot.

The program input is transformer-coupled; it will also accept an unbalanced input if you ground either of the hot leads. A 0 dB signal will drive the headset/speaker to full output. The impedance of the program input is 10k ohms bridging.

The program audio mixes with the intercom audio (in the station's headset and speaker outputs only), and the listen-levels of each are adjustable via the RM-120A front panel controls.

- 4) **Stage Announce** connection from rear panel: output to speaker/amp paging system (600 ohms impedance); ring/tip/sleeve connections.

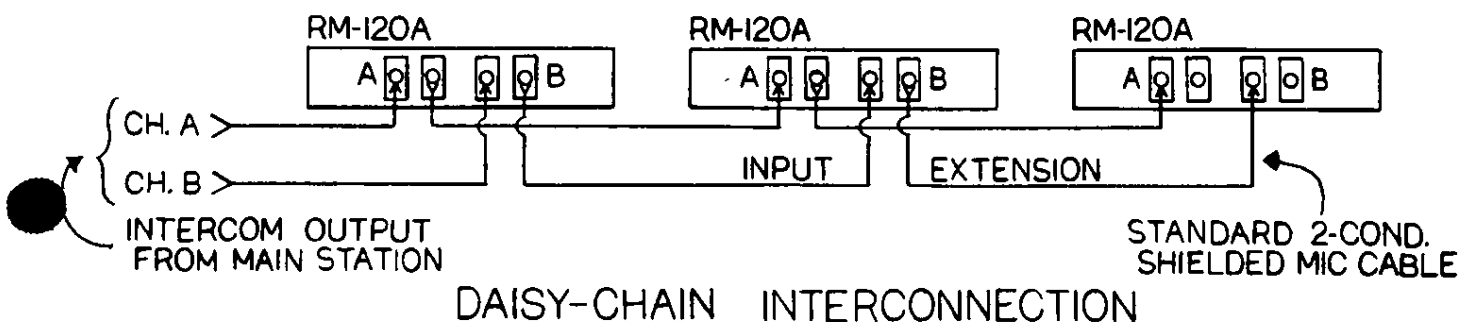

IV. RM-120A OPERATING CONTROLS & CONNECTORS

The RM-120A controls and connectors are described below in the order in which they appear on the FRONT PANEL from LEFT to RIGHT.

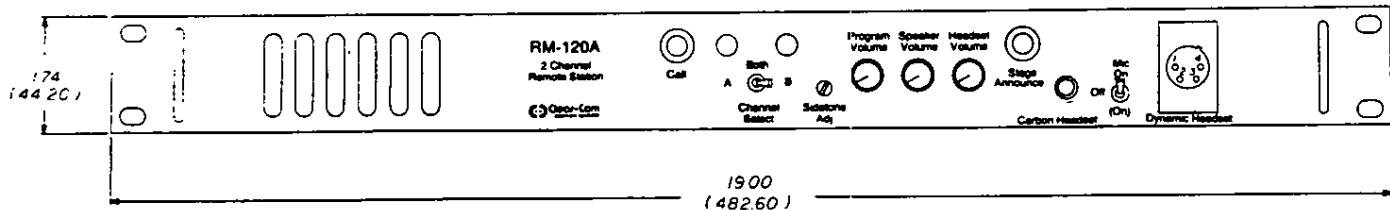

Call

The Call push-button activates visual signalling. It allows the intercom user to attract the attention of operators who've removed their headsets or turned off their speakers. The Call button can also control the speaker or mic at KB-112 Stations set up for remote control.

The Call signal follows the position of the "Channel Select" switch; if you using Channel A, the Call button causes the lamps to light at all other stations using Channel A (and likewise for Channel B). When the Channel Select switch is set to "both," the lamps at all stations on both channels shine simultaneously. The Call signal is active for as long as you keep your finger on the Call button.

Receiving Signals: The amber Call lamp on the left, for Channel A, lights when any station on that channel activates the Call circuit. The amber Call lamp on the right, for Channel B, lights up when any Channel B station activates Call. They operate independently of the setting of the Channel Select switch.

Note: an internal jumper reverses the Call function for use with KB-112 remote control-- call Clear-Com for info.

Channel Select

This 3-position toggle switch assigns the RM-120A speaker/headset monitoring function to (1) **Channel A**, (2) **Channel B**, or (3) **both channels** (RM-120A operator can talk/listen to stations on Channel A and stations on Channel B, but Channel A stations cannot talk/listen to Channel B stations-- unless a Party Line system has been set up via the Main Station).

Sidetone Adj

The sidetone adjustment, which is controlled with the blade of a small screwdriver, allows the RM-120A operator to add back a fixed level of his/her voice in the speaker or headset, regardless of which channels are selected. When using the gooseneck and speaker simultaneously, this control should be turned all the way down to further reduce the possibility of feedback.

Internal Trimpots (schematic reference, P5 and P6): One sidetone null control per channel; you need only adjust the sidetone once at the time of installation (if at all), even if other stations subsequently join or leave the intercom system. Adjusting the sidetone does not affect the level of incoming or outgoing signals.

(continued)

At the factory, Clear-Com sets the internal sidetone null to the best overall null with 500 feet of cable. If the sidetone is not nulled enough, feedback may occur between the speaker and the mic. To adjust the internal sidetone null:

- 1) remove top cover of unit
- 2) plug in headset and turn on mic (or activate gooseneck mic)
- 3) turn up Headset Volume
- 4) talk into mic while slowly turning sidetone adjustment clockwise. Find the null point where you can barely hear yourself. This is the proper setting for minimum feedback when using both the speaker and a mic. Adjust individually for each channel.

Program Volume

Speaker Volume

Headset Volume

These knobs adjust listen-levels of the auxiliary program and overall intercom activity, as heard in the speaker and headphones.

Stage Announce

This push-button activates the feature designed for paging applications. The RM-120A provides a balanced, line-level output signal to a 1/4" phone jack on its rear panel. The Stage Announce button activates this output, giving the operator access (via headset or gooseneck mic) to the external speaker/amp system. Pressing Stage Announce also mutes the operator's voice to the intercom channels.

Mic On/Off/(On)

This 3-position toggle switch turns the mic on or off in your carbon and dynamic headset or the gooseneck mic. With the switch set to the top "on" position, the mic stays on. When in the middle position, the mic is off. The bottom position "(on)" is a momentary setting.

PROGRAM INPUT

3-pin female XLR connector; pin-out assignment is:

Pin 1--ground

Pin 2--input

Pin 3--input

The auxiliary program input is on the RM-120A rear panel. It accepts a balanced, line-level input (input impedance is 10k ohms bridging; a 0 dBv nominal signal drives the headset to full output). The RM-120A operator can monitor program along with intercom activity in the headset/speaker. A split-feed option, set up at the Clear-Com factory, separates the intercom and program signals for use with a binaural (6-pin, stereo) dynamic headset.

STAGE ANNOUNCE OUTPUT

1/4" phone jack; 3-circuit (ring/tip/sleeve); 600 ohms output impedance.

EXTERNAL SPEAKER OUTPUT

1/4" phone jack; 2-circuit (internally-switched; ring/tip); disconnects internal speaker; output for speaker with impedance of 8 ohms or more (preferably 16 ohms).

V. RM-120A SPECIFICATIONS

AMPLIFIER DESIGN

Solid-state, integrated circuit amplifiers which include a mic pre-amp with limiter, headset power amp, speaker power amp, and signalling circuitry. Current-limited with short-circuit and reverse polarity protection.

MIC PRE-AMPLIFIER

Freq. Response: 250-12k Hz, with mic limiter; contoured to enhance intelligibility
Mic Input Impedance: 1k ohms
Mic Preamp Gain: +37 dB
Max Input Before Clipping: -10 dBV*
Mic Limiter Range: 25 dB

HEADSET/SPEAKER AMPLIFIER

Freq. Response: 100-18k Hz, ±2 dB
Load Impedance Range: 300-2000 ohms (dynamic headset)
Output Level: +18 dBm, 26v p-p @ 200 ohms
Headset Level: +110 dB SPL (with standard Clear-Com headset)
Headset Distortion: 0.2% THD @ 1kHz
Headphone Amp Gain: +37 dB
Speaker Type: 16 ohm, 3"x 1.5" oval
Spkr. Amp Output: 2.5w into 16 ohms
Speaker Level: +98 dB SPL @ 3 feet

GENERAL SPECS

Line Level: 0dBv max, -18dBv nom.
Sidetone Adj: 35 dB null to full on
Signal Voltage: 11VDC on audio line
Call Light Sensitivity: 4 volts
Signal-to-Noise: 68 dB
Equivalent Input Noise: -118 dB
Station Bridging Impedance: >12k ohm (200-10k Hz)
Power Requirements: 25 mA quiescent
100 mA signal, 100 mA avg. talk
200 mA short-circuit
Voltage Range: 12-32V, 28V nominal
Dimensions: 1.75" x 19" x 6.5" deep
44 mm x 483 mm x 165 mm

CONNECTORS

Dynamic Headset: 4-pin XLR, male
Carbon Headset: 1/4" phone jack
Line: (4) 3-pin XLR
Channel A--1 male, 1 female
Channel B--1 male, 1 female
Program Input: 3-pin XLR, female
Ext. Speaker: 1/4" phone jack (disconnects internal speaker)

* 0 dBv is referenced to 0.775 volts RMS

VI. RM-120A PARTS LISTING

| Part # | Description | Qty. | Schematic Reference ID |
|--------|--|------|------------------------|
| 210002 | Conn, intercom/prgm, D3F | 3 | |
| 210003 | Conn, intercom, D3M | 2 | |
| 210013 | Conn., headset, D4M | 1 | |
| 210050 | Conn., 1/4" phone jack | 2 | J1, stage announce |
| 210055 | Conn., 1/4" jack w/switch | 1 | ext. speaker |
| 240015 | Knob, black, 1/2" | 3 | P1, P2, P3 |
| 240017 | Handle, chrome | 2 | |
| 250128 | RM-120A rear panel | 1 | |
| 250224 | RM-120A front panel | 1 | |
| 250073 | Chassis mainframe, 1.75" | 1 | |
| 250152 | Chassis top cover | 1 | |
| 250163 | Speaker screen | 1 | |
| 390013 | Lamp lens, amber (390012 Bulb, 28v) | 2 | L1, L2 |
| 500095 | Speaker, 16 ohm, oval | 1 | |
| 510012 | Switch, momentary pushbutton | 2 | H5 (call) |
| 640028 | Hole plug, 3/4" | 1 | (without gooseneck) |
| 710054 | Gooseneck Mic | 1 | (optional) |
| 710158 | RM-120A electronics assy. | 1 | |
| 810031 | RM-120A instruction manual | 1 | |

| REVISIONS | | DATE | APPROVED |
|-----------|-----------------|----------|----------|
| 1 | PROTO | 5-5-64 | |
| 2 | RELEASE ECO 700 | 8-27-64 | |
| 3 | ECO 711 | 9-4-64 | |
| 4 | ECO 745 | 11-20-64 | MMW |

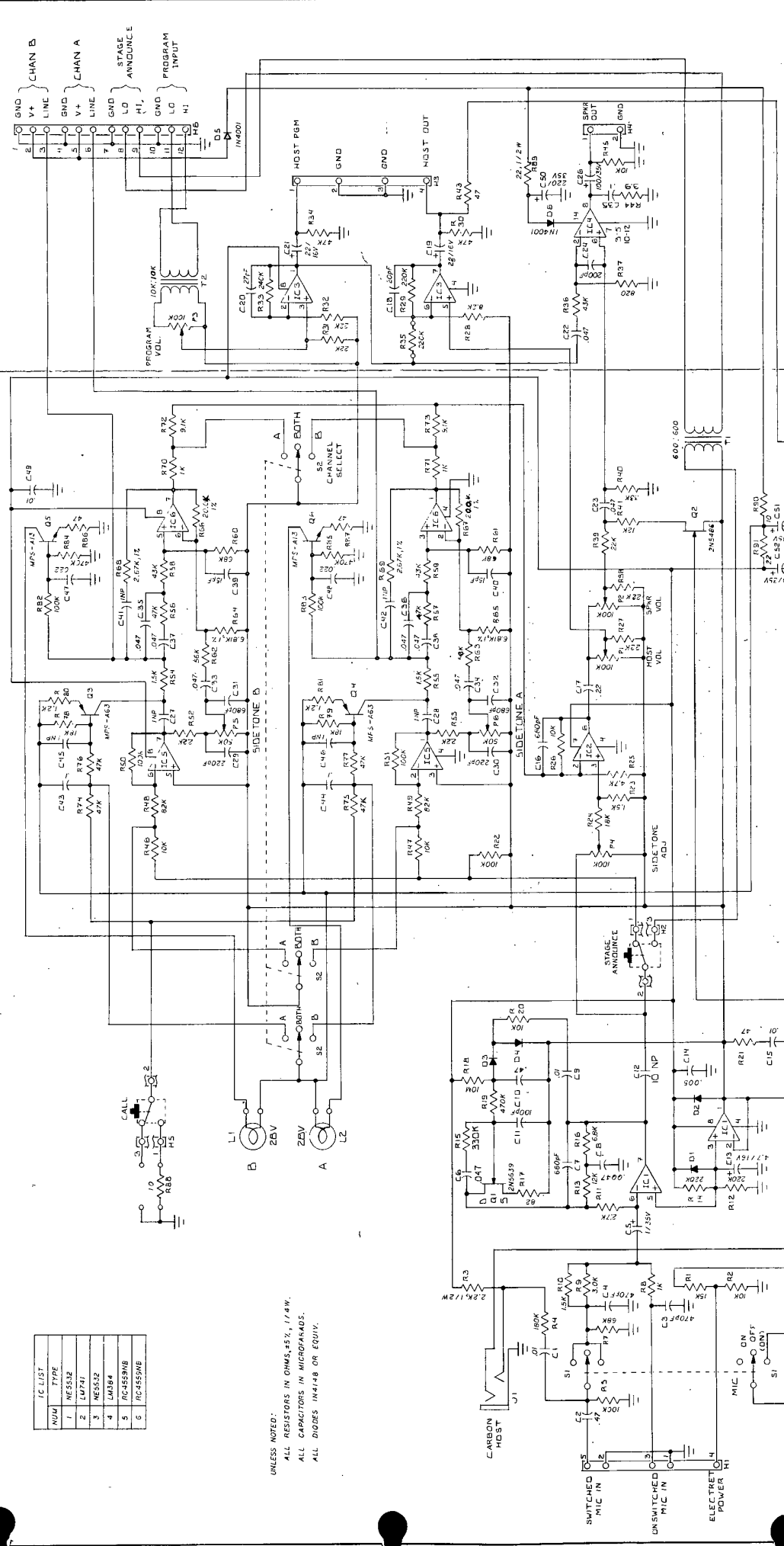

| NUM | TYPE |
|-----|---------|
| 1 | NESS32 |
| 2 | LUT41 |
| 3 | NESS32 |
| 4 | LUR84 |
| 5 | IC4559B |
| 6 | IC4559B |

UNLESS NOTED:
 ALL RESISTORS IN OHMS, 5%, 1/4W.
 ALL CAPACITORS IN MICROFARADS.
 ALL DIODES IN4148 OR EQUIV.

Clear-Com
 COMMUNICATION SYSTEMS

RM-1820 PCB SCHEMATIC
 SIZE 7.0199-SC.D.D.C
 SCALE 1:1
 DO NOT SCALE DRAWING

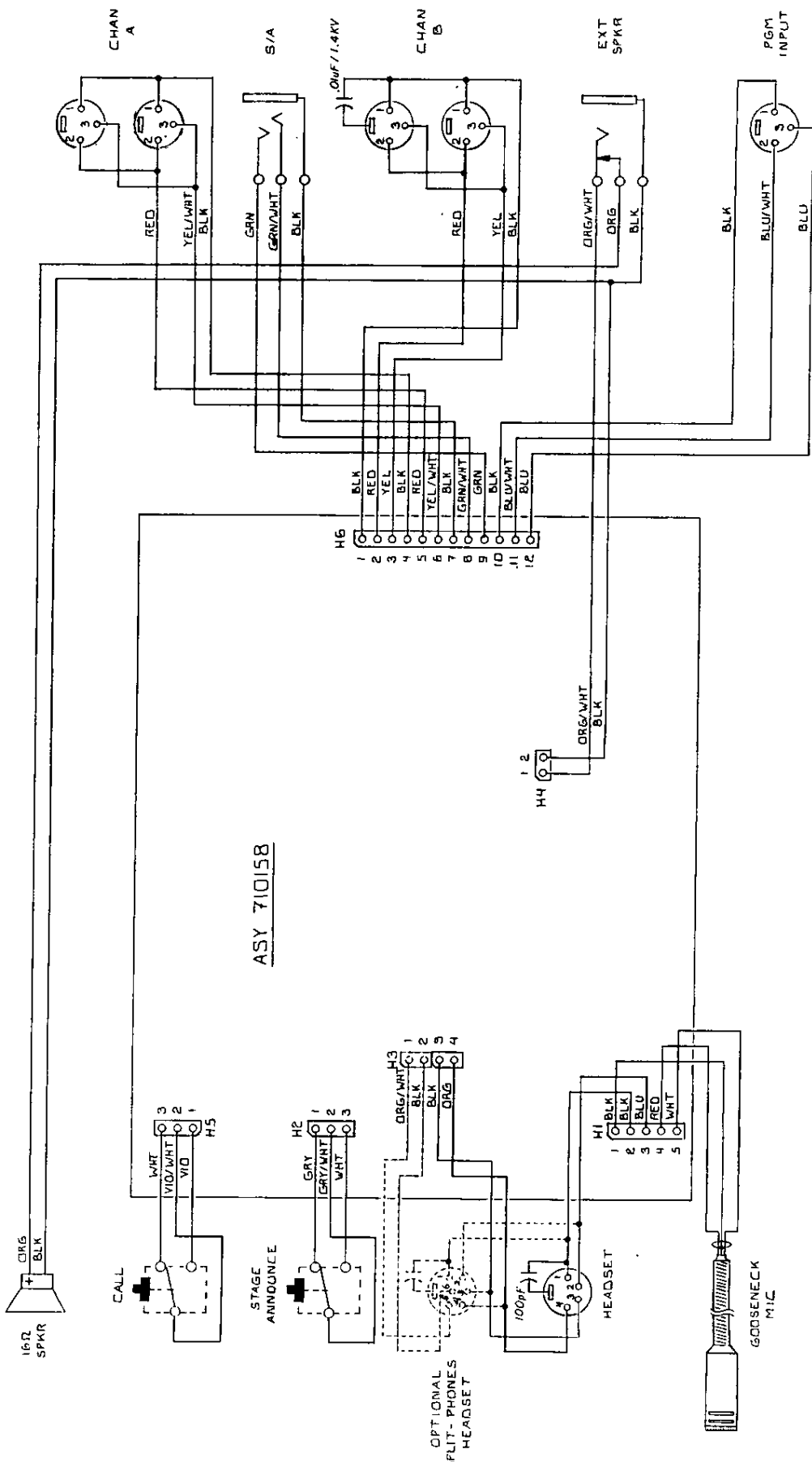

NOTE:
FOR UNITS WITHOUT
A GOOSENECK MIC,
H1 IS WIRED THUSLY

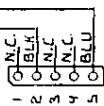

TO HOST CONN

Clear-Com
intercom systems

RM-120A
SYSTEM SCHEMATIC

SCALE: 1/2" = 1'-0"

SIZE: C
DRAWING NO.: RM120A-550-C-A

DO NOT SCALE DRAWING

SHEET 1 OF 1