

# 3M™ Water Filtration Products

## Installation and Operation Instructions for High Flow Series

### Dual Flow Manifold System DF260-CL-CC

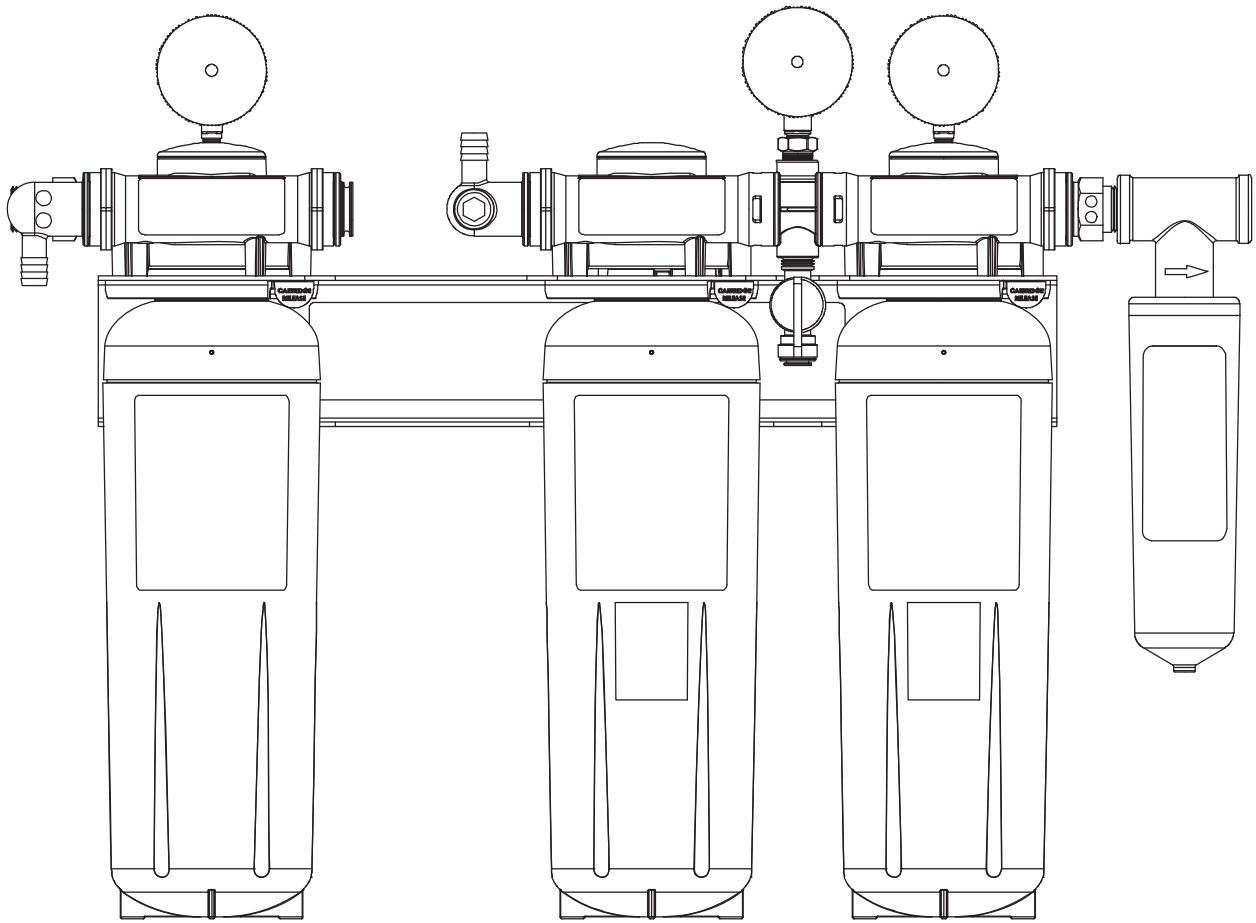

Installer: Please leave this manual with owner/operator.

Owner/Operator: Please retain for operation and future instructions.

# NOTES



---

# SAFETY INFORMATION

Read, understand, and follow all safety information contained in these instructions prior to installation and use of the 3M™ Water Filtration Products Dual Flow Manifold System DF260-CL-CC. Retain these instructions for future reference.

## Intended use:

The **Dual Flow Manifold System** DF260-CL-CC is intended for use in filtering potable water for foodservice equipment and has not been evaluated for other uses. The system is installed indoors, and must be installed by a qualified professional installer according to these installation instructions.

<b>EXPLANATION OF SIGNAL WORD CONSEQUENCES</b>	
 <b>WARNING</b>	Indicates a potentially hazardous situation, which, if not avoided, could result in death or serious injury and/or property damage.
 <b>CAUTION</b>	Indicates a potentially hazardous situation which, if not avoided, may result in minor or moderate injury and/or property damage.
<b>CAUTION</b>	Indicates a potentially hazardous situation, which, if not avoided, may result in property damage.

 <b>WARNING</b>
<b>To reduce the risk associated with the ingestion of contaminants:</b> <ul style="list-style-type: none"><li>• <b>Do not use with water that is microbiologically unsafe or of unknown quality without adequate disinfection before or after the system.</b> Systems certified for cyst reduction may be used on disinfected water that may contain filterable cysts. EPA Establishment #070595-CT-001</li></ul>
<b>To reduce the risk associated with choking:</b> <ul style="list-style-type: none"><li>• <b>Do not</b> allow children under 3 years of age to have access to small parts during the installation of this product.</li></ul>
<b>To reduce the risk associated with hazardous voltage due to an installer drilling through existing electric or water pipes in the area of installation:</b> <ul style="list-style-type: none"><li>• <b>Do not</b> install near electric wiring or piping which may be in path of a drilling tool when selecting the position to mount the system bracket.</li></ul>
<b>To reduce the risk of physical injury:</b> <ul style="list-style-type: none"><li>• Depressurize system as shown in manual prior to cartridge removal.</li></ul>
<b>To reduce the risk associated with back strain:</b> <ul style="list-style-type: none"><li>• Follow safe lifting procedures.</li></ul>

## CAUTION

### To reduce the risk associated with property damage due to water leakage:

- **Read and follow** Use Instructions before installation and use of this system.
- Installation and use **MUST** comply with all state and local plumbing codes.
- Before starting installation, shut off main water supply and drain pipes.
- **Protect from freezing**, remove filter cartridge when temperatures are expected to drop below 40 °F (4.4 °C).
- **Do not** install systems in areas where ambient temperatures may go above 110 °F (43.3 °C).
- **Do not install on hot water supply lines**. The maximum operating water temperature of this system is 100 °F (37.8 °C).
- **Do not** install if water pressure exceeds 125 psi (862 kPa). If your water pressure exceeds 80 psi (552 kPa), you must install a pressure limiting valve. Contact a plumbing professional if you are uncertain how to check your water pressure.
- **Do not install** where water hammer conditions may occur. If water hammer conditions exist you must install a water hammer arrester. Contact a plumbing professional if you are uncertain how to check for this condition.
- Any non-metallic fittings used in the installations must be of adequate rating for the line pressure.
- Where a backflow prevention device is installed on a water system, a device for controlling pressure due to thermal expansion must be installed.
- **Do not** use a torch or other high temperature sources near system, cartridges, plastic fittings or plastic plumbing.
- On plastic fittings, never use pipe sealant or pipe dope. Use PTFE thread tape **only**, pipe dope properties may deteriorate plastic.
- Take care when using pliers or pipe wrenches to tighten plastic fittings, as damage may occur if over tightening occurs.
- **Do not install** in direct sunlight or outdoors.
- **Do not install** near water pipes which will be in path of a drilling tool when selecting the position to mount the bracket.
- Mount system in such a position as to prevent it from being struck by other items used in the area of installation.
- Ensure that the location and fasteners will support the weight of the system when installed and full of water.
- Ensure all tubing and fittings are secure and free of leaks.
- **Do not install** unit if collet is missing. Contact your sales representative if collets are missing from any fittings.
- The disposable filter cartridge(s) **MUST** be replaced every 12 months, at the rated capacity, or sooner if a noticeable drop in pressure occurs.

## IMPORTANT NOTES

- Failure to follow instructions will void warranty.
- Allow a minimum of 3" (7.6 cm) clear space under filter to facilitate cartridge change.
- Install with the inlet and outlet ports as labeled. Make sure not to reverse connections.
- Some local codes may require the use of a licensed plumber or certified installer when disrupting a potable water line.

# Table of Contents

Safety Information.....	1	Equipment Installation.....	5
Dual Flow (DF) Manifold Systems and Cartridges.....	3	Cartridge Change-out Procedure.....	6
Inlet and Outlet Connections.....	3	Troubleshooting.....	7
Product Dimensions.....	3	Replacement Parts Listing.....	7
How to Use “Push-in” Connections.....	4	Limited Warranty.....	8
How to Use “Inlet/Outlet” Fitting Retention Clips.....	4		

## Dual Flow (DF) Manifold System and Cartridges

The DF260-CL-CC Dual Flow (DF) System helps to provide consistent high quality water for multiple applications. The inlet water for the ice machine enters the manifold on the left rear side, and the inlet water for the beverage and coffee enters the manifold on the right rear side. Each water stream (ice, beverage, coffee) has a separate outlet connection fitting.

The left single cartridge (yellow label) is model HF60-S-SR5. It is critical that this cartridge be installed in the left most manifold head which also has a yellow 3M label. The cartridge is keyed such that it will not fit properly if installed in either of the other manifold heads. The media in this cartridge is a pleated nylon membrane with a time released scale inhibitor. It filters the water going to the ice machine. The water for the ice machine exits the manifold on the left side front connection (labeled “Outlet Ice”).

The two cartridges to the right of the ice cartridge (blue label) are model HF60-CL. These cartridges are plumbed in parallel and filter the water going to post mix cold beverage and coffee. The HF60-CL cartridges will not fit into the left most (ice) head. The water for cold beverage exits the manifold on the middle front connection (labeled “Outlet Beverage”). Water for coffee exits the manifold on the right side front connection (labeled “Outlet Coffee”).

## Inlet and Outlet Connections

The water inlets are on the rear left and right sides, and the water outlets are on the front right, middle, and left sides. All inlets and outlets are identified with their corresponding labels. The water inlets fitting size is 3/4" NPT male, the ice and beverage outlet fitting size is 1/2" barb, and the coffee outlet fitting size is 3/4" NPT female. Built-in check valves (non-return) are incorporated into all three outlets.

## Product Dimensions

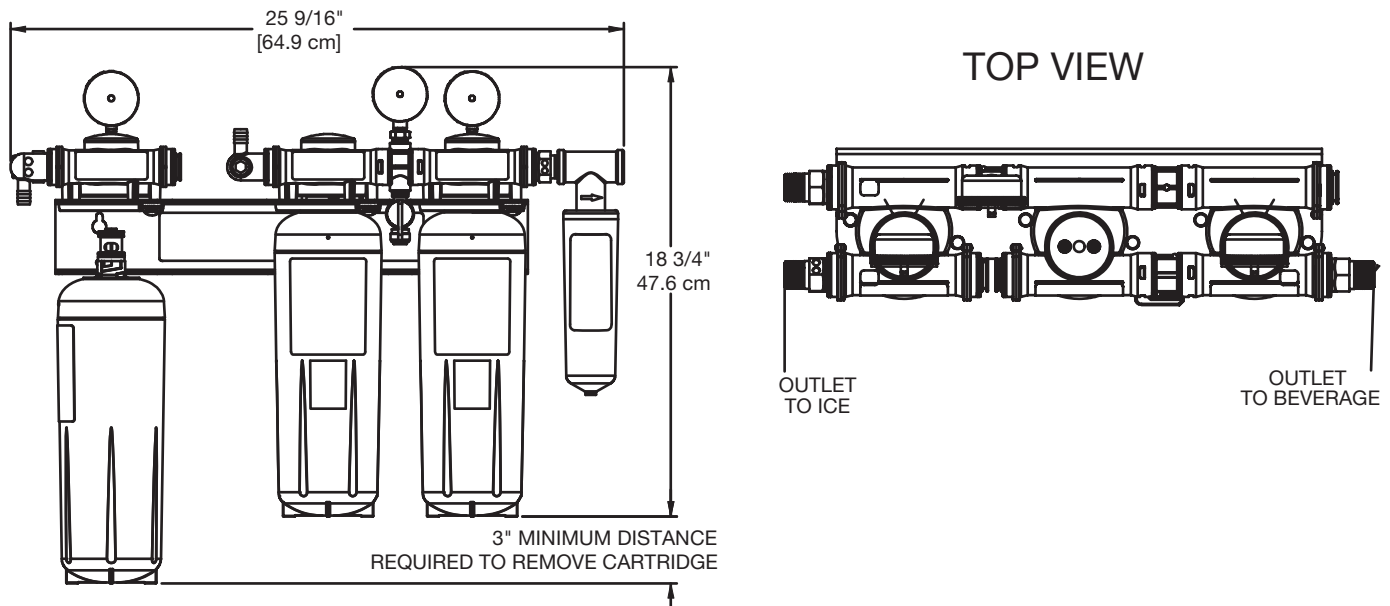

Figure 1  
3

## How To Use “Push-In” Fittings (Collet)

### CAUTION

To reduce the risk associated with property damage due to water leakage:

- Do not install unit if collet is missing. Contact your sales representative if collets are missing from any fittings.

This product is outfitted with user friendly “push-in” connectors. Proper use of the connectors is shown in Figure 2. It is most important that the tubing selected for use with these connectors be of high quality, exact size and roundness, and with no surface nicks or scratches. If it is necessary to cut the tubing, use a plastic tubing cutter or sharp razor knife. Make a clean square cut. Should a leak occur at a “push-in” connector, the cause is usually due to the tubing. To fix tubing, relieve the pressure within the tube. Release the end of the tubing with the leak from its “push-in” connector. Cut off at least 1/4” (0.6 cm) from the end. Reattach the tubing to its “push-in” connector. Confirm connection is leak free.

### To Attach Tubing

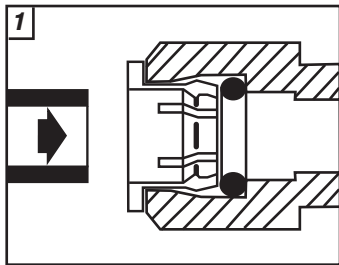

Push tubing straight as far as it will go.

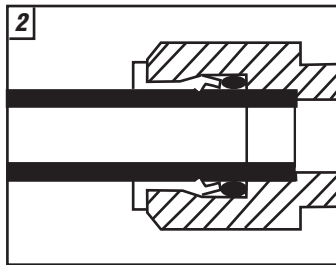

Tubing is secured in.

### To Release Tubing

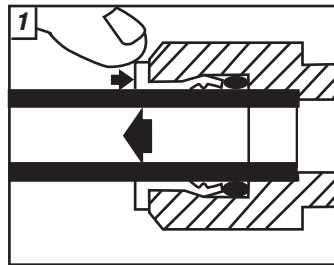

Push in grey collet to release tubing.

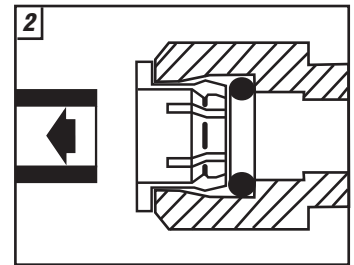

Pull tubing straight out.

Figure 2

## How to Use the Inlet/Outlet Fitting Retention Clips

This product is outfitted with inlet/outlet fittings. The fittings can be attached or removed from the system without tools. Retention clips are semi-circular in shape with three internal tabs, bottom, center and top. Tab interlaces with windows in the manifold head near each connection port. Clip is flexible and easily assembled following these instruction and illustrations.

1. Insert fitting into manifold.
2. With fitting inserted into manifold port, snap clip into place beginning at the bottom slot.
3. Push center tab into center slot.
4. Finally push top tab into top slot.

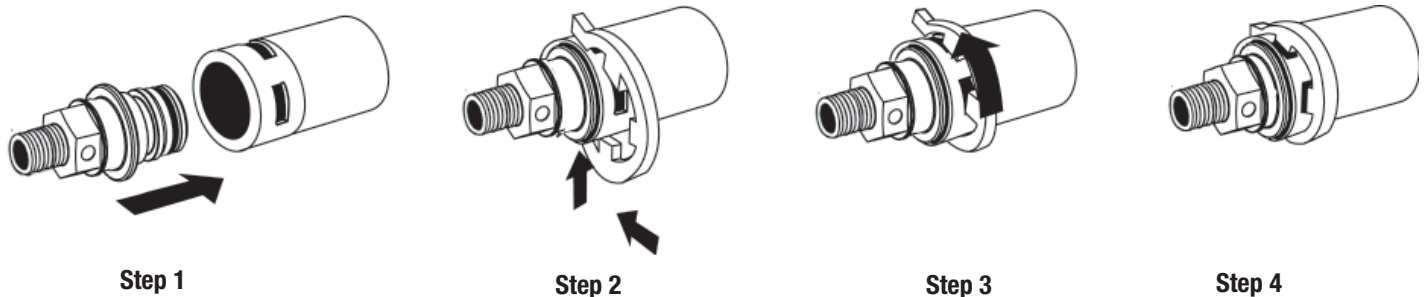

Figure 3

# Equipment Installation

## CAUTION

To reduce the risk associated with property damage due to water leakage:

- Read, understand, and follow all safety information contained on pages 1-2 prior to installation and use of this product.

## IMPORTANT NOTES

- Failure to follow instructions will void warranty.
- Allow a minimum of 3" (7.6 cm) clear space under filter to facilitate cartridge change.
- Install with the inlet and outlet ports as labeled. Make sure not to reverse connections.

DF manifold systems may be used with metal or non-metallic piping systems.

1. Shut off incoming cold water supply.
2. Select the installation location. Allow a minimum of 3 in (7.6 cm) of space below the cartridge for change-outs.
3. Select fasteners (not included) and tools appropriate for the installation location (wall, support structure mounted to wall studs, concrete, etc.)
4. Mount the manifold/filter system to a wall or using the mounting holes provided on the back plate of the metal bracket.
  - It is recommended to first draw a level line on the mounting surface at the height of the fasteners.
  - Mark the location of the fasteners using the bracket as a template or by measuring the distance between the mounting holes.
  - Install the fasteners and allow 1/4"-3/8" (6-10 mm) of each fastener to protrude from the surface.
  - Install the manifold onto the fasteners.
  - Tighten the fasteners.
5. Install 3/4" NPT male inlet fittings for the ice water inlet and the beverage/coffee water inlet (left and right rear respectively). Install a 1/2" Barb fitting for the ice water outlet, a 1/2" Barb fitting for the beverage water outlet, and a 3/4" NPT female fitting for the coffee water outlet (left, middle and right front respectively). The inlet Connection Kit (CCP# 125830) includes the 1/2" Barb fittings and the two inlet ball valves. The three system outlets include the fittings only. The instructions for the retention clips are on page 4. (PTFE tape is not included).
6. Remove the sanitary cap from the HF60-S-SR5 cartridge (cartridge with yellow label) and apply a light coat of water or food-grade lubricant to the o-rings.
7. Align the tabs on the HF60-S-SR5 cartridge with the slots in the retaining plate of the head on the left hand manifold head (NOTE: Head has yellow 3M label adhered to it). Insert the cartridge into the head and turn the cartridge to the right until a click sound is heard; the click indicates that the cartridge is properly engaged.
8. Repeat Steps 6 & 7 for the HF60-CL beverage cartridges into the two heads on the right side of the manifold. NOTE: The HF60-CL cartridges need to be installed into the heads with the blue 3M labels adhered to them.

## Equipment Start-up Procedure

1. Turn on incoming water to system.
2. Pressurize system by opening inlet valves for both the ice and cold beverage/coffee water inlets.
3. Check for leaks.
4. Use vent valve to remove trapped air.
5. Flush system in accordance with the cartridge Performance Data Sheet.

# Cartridge Change-out Procedure

## CAUTION

To reduce the risk associated with property damage due to water leakage:

- The disposable filter cartridge **MUST** be replaced every 12 months or sooner at the rated capacity or if a noticeable reduction in flow rate occurs.

## IMPORTANT NOTE:

The ice cartridge (Model HF60-S-SR5) has a yellow label and will only fit into the head on the left side of the manifold (head has a yellow 3M label). The Beverage cartridges (Model HF60-CL) will only fit into the heads on the right side of the manifold (heads have a blue 3M label).

### DF260-CL-CC System Shut-Off procedure:

Cartridges will need to be changed at least every 12 months or when low pressure is indicated on the manifold's pressure gauge, whichever occurs first. Depending on local water quality, you may need to change the cartridges prior to the recommended change-out. The loss of flow to carbonators or improper fill at the ice maker are also indicators that the cartridges will need to be replaced.

1. Shut-off ice, beverage, and coffee water inlet valves (2 total).
2. Shut-off ice, beverage, and coffee water outlet valves (3 total).
3. Replace HF60-S-SR5 (yellow label), HF60-CL (blue label), and HF8-S cartridges in the sequence shown below. Then complete DF260-CL-CC System Pre-Start-Up procedure as shown below before starting system back up.

### HF60-S-SR5 Cartridge (yellow label) Replacement:

1. Relieve pressure in the ice line by opening and closing the ice outlet flush valve.
2. Push and hold yellow tab to release cartridge locking mechanism while simultaneously rotating cartridge to the left.
3. Using both hands and holding the cartridge from the bottom, rotate the cartridge a quarter turn to the left and gently pull down. NOTE: A small amount of water will drain from manifold as cartridge is removed.
4. Remove sanitary cap from new cartridge. Install with a quarter turn to the right until cartridge comes to a complete stop. NOTE: Cartridges are keyed to fit in proper location only.

### HF60-CL Cartridge (blue label) Replacement:

1. Relieve pressure to beverage/coffee line by opening and closing the flush valve in between the HF60-CL cartridges.
2. Push and hold yellow tab to release cartridge locking mechanism while simultaneously rotating cartridge to the left.
3. Using both hands and holding the cartridge from the bottom, rotate the cartridge a quarter turn to the left and gently pull down. NOTE: A small amount of water will drain from manifold as cartridge is removed.
4. Remove sanitary cap from new cartridge. Install with a quarter turn to the right until cartridge come to a complete stop. NOTE: Cartridges are keyed to fit in proper location only.
5. Repeat steps 2-4 for second HF60-CL cartridge

### HF8-S Cartridge Replacement:

1. Open downstream valve to relieve pressure.
2. Unscrew cartridge by turning clockwise. NOTE: A small amount of water will drain when HF8-S cartridge is removed.
3. Lubricate o-ring of new cartridge with water.
4. Install by turning new HF8-S cartridge toward the right until it come to a complete stop. Do not over tighten. (never use tools to tighten cartridge)



## DF260-CL-CC System Pre-Start-Up procedure:

1. Turn ice water inlet valve ON.
2. Remove trap air in the ice line by opening and closing the ice outlet flush valve.
3. Turn ice water outlet valve ON.
4. Turn beverage/coffee water inlet valve ON.
5. Remove trap air in the beverage line by opening and closing the beverage outlet flush valve.
6. Turn beverage water outlet valve ON.
7. Turn coffee water outlet valve ON
8. Slowly turn the beverage/coffee inlet water valve ON and check for leaks.
9. Slowly turn the ice inlet water valve ON and check for leaks.
10. Flush per the cartridge Performance Data Sheet and check for leaks. System is now ready for use.

## Troubleshooting

---

No water flow through system	Inlet valve closed Cartridges clogged	Check shut-off valve position Replace cartridges
Not enough water to the downstream application(s)	Low incoming water pressure Cartridges clogged	Check source Replace cartridges
Short filter life	Temporarily dirty water	Change cartridges or install an additional upstream prefilter

## Limited Warranty

---

3M Purification Inc. warrants this Product (excluding disposable filter cartridges(s) or membranes(s)) will be free from defects in material and manufacture for five (5) years from the date of purchase. The disposable filter cartridge or membrane is warranted from defects in material and manufacture for a period of one (1) year from the date of purchase. This warranty does not cover failures resulting from abuse, misuse, alteration or damage not caused by 3M Purification Inc. or failure to follow installation and use instructions. No warranty is given as to the service life of any filter cartridge or membrane as it will vary with local water conditions and water consumption. **3M PURIFICATION INC. MAKES NO OTHER WARRANTIES OR CONDITIONS, EXPRESS OR IMPLIED, INCLUDING, BUT NOT LIMITED TO, ANY IMPLIED WARRANTY OR CONDITION OF MERCHANTABILITY OR FITNESS FOR A PARTICULAR PURPOSE OR ANY IMPLIED WARRANTY OR CONDITION ARISING OUT OF A COURSE OF DEALING, CUSTOMER OR USAGE OF TRADE.** If the Product fails to satisfy this Limited Warranty during the warranty period, 3M Purification Inc. will replace the Product or refund your Product purchase price. This warranty does not cover labor. **The remedy stated in this paragraph is Customer's sole remedy and 3M Purification Inc.'s exclusive obligation.**

This warranty gives you specific legal rights, and you may have other rights which may vary from state to state, or country to country. For any warranty questions, please call (866) 990-9785 or mail your request to: Warranty Claims, 3M Purification Inc., 400 Research Parkway, Meriden, CT 06450. Proof of purchase (original sales receipt) must accompany the warranty claim, along with a complete description of the Product, model number and alleged defect.

### Limitation of Liability.

3M Purification Inc. will not be liable for any loss or damage arising from this 3M Purification Inc. product, whether direct, indirect, special, incidental, or consequential, regardless of the legal theory asserted, including warranty, contract, negligence or strict liability. Some states and countries do not allow the exclusion or limitation of incidental or consequential damages, so the above limitation or exclusion may not apply to you.

### Important Notice

The information described in this literature is accurate to the best of our knowledge. A variety of factors, however, can affect the performance of the Product(s) in a particular application, some of which are uniquely within your knowledge and control. **INFORMATION IS SUPPLIED UPON THE CONDITION THAT THE PERSONS RECEIVING THE SAME WILL MAKE THEIR OWN DETERMINATION AS TO ITS SUITABILITY FOR THEIR USE. IN NO EVENT WILL 3M PURIFICATION INC. BE RESPONSIBLE FOR DAMAGES OF ANY NATURE WHATSOEVER RESULTING FROM THE USE OF OR RELIANCE UPON INFORMATION.**

It is your responsibility to determine if additional testing or information is required and if this product is fit for a particular purpose and suitable in your specific application.



#### 3M Purification Inc.

400 Research Parkway  
Meriden, CT 06450, U.S.A.  
Tel (866) 990-9785  
(203) 237-5541  
Fax (203) 238-8977  
[www.cunofoodservice.com](http://www.cunofoodservice.com)  
[www.3Mpurification.com](http://www.3Mpurification.com)

3M is a trademark of 3M Company.  
© 2011 3M Company. All rights reserved.  
Please recycle. Printed in U.S.A.  
INSTR4382 0411